

Research Article

# Optimal Control in SEIT Type Epidemic Model with Different Exposed Periods and Saturated Incidence Rates

Yuliana Trisanti<sup>1\*</sup>, and Latifatul Mammunah<sup>2</sup>, Mohammad Nazir Arifin<sup>3</sup>

<sup>1</sup> Department of Management, Universitas Madura, Pamekasan, Indonesia, 69371

<sup>2</sup> Department of Civil Engineering, Universitas Madura, Pamekasan, Indonesia, 69371

<sup>3</sup> Department of Informatics, Universitas Madura, Pamekasan, Indonesia, 69371

\*Corresponding Author: [yuli@unira.ac.id](mailto:yuli@unira.ac.id) | Phone: +6285284000676

## ABSTRACT

The mathematical model of infectious disease spread used in this study is the SEIT (Susceptible Exposed Infective Treatment) type epidemic model with a saturated incidence rate. Optimal treatment control is given to the exposed and infective populations with the same treatment rate with the aim of minimizing the number of infective individuals and treatment costs. By applying the Pontryagin Principle, optimal control and system are obtained. The rate of population change in the model is illustrated by numerical simulations.

**Keywords:** Epidemic models; SEIT; optimal control; Pontryagin's principle

## 1. INTRODUCTION

Infectious diseases are diseases caused by a biological agent, such as a virus, bacteria, or parasite. An individual can contract an infectious disease through direct or indirect contact with an infected individual. As a result of contact between individuals, a new infection occurs which is a sign of a case of the spread of an infectious disease. The continued spread of infectious diseases will result in a condition called an epidemic. An epidemic is an event where an infectious disease spreads in a community where the number of sufferers increases significantly beyond the usual conditions at a certain time and area. If the spread of the disease does not disappear and the number of infected people remains stable, then a disease is said to be in an endemic state (Fathoni et al., 2014)

The emergence of the disease has received attention from various groups, especially experts in the medical field who do have an important role in preventing the spread of the disease. The development of science in mathematics also plays an important role in preventing the spread of the disease. This role is in the form of a mathematical model that can describe the spread of a disease in the future by looking at current or past conditions. This mathematical model is called an epidemic model (Fathoni et al., 2014)

The epidemic model was first introduced in 1927 by Kermack and McKendrick, namely the SIR (Susceptible Infective Removal) model. The SIR model describes a disease spread where susceptible individuals can be infected through the process of interaction with infected individuals, then the recovered population (removal) has immunity to a disease so that these individuals will not return to being a population susceptible to the disease (Kermack and McKendrick, 1927). The increasing development of research on disease spread models has made the SIR model a basis for many scientists to create more specific epidemic models.

For other cases of disease, infected individuals can recover. However, there is no guarantee that individuals who recover from the disease will be immune to the same disease. Therefore, individuals who recover will re-enter the vulnerable population. Some infectious diseases have an exposed period. The exposed period or also called the latent period is the period when the disease hides in the body when the immune system is in good condition. The existence of the exposed period is the reason for the formation of the SEIS (Susceptible Exposed Infective Susceptible) type epidemic model (Fan, Li, and Wang, 2001).

In general, epidemic models consider the incidence rate of disease infection. The incidence rate of infection states the number of new cases of infection due to interactions between susceptible individuals and infected individuals. Capasso and Serio (1978) introduced a nonlinear infection incidence rate called the saturated infection incidence rate. This type of incidence rate is more effective because it considers behavioral changes and the influence of the density of infected individuals (Capasso and Serio, 1978). In recent years, the spread of infectious diseases has occurred in various forms, such as in the H1N1 disease. The diversity that occurs is the difference in the exposed period in each individual's body infected

with the H1N1 virus. There are individuals who go through the exposed period phase, and some do not. This occurs because of the variation of the virus and the different physical conditions of each individual. Wang (2012) has modeled the spread of SEIS-type infectious diseases with differences in the exposed period and the saturated incidence rate.

The spread of a disease can be controlled by administering drugs to infected individuals. Therefore, treatment needs to be carried out as an effort to prevent the spread of the disease. The epidemic model with treatment gives rise to a new population of infected individuals who have received treatment, namely the treatment population, so that a SEIT (Susceptible Exposed Infective Treatment) type epidemic model is formed. Treatment is often constrained by costs, so it is not necessarily economically optimal. Thus, it is necessary to determine the optimal treatment so that the costs required are minimal but the treatment carried out remains effective as a control of the spread of the disease. The spread of SEIT type infectious diseases with differences in exposed periods and saturated incidence rates has been modeled by Fathoni, Mardlijah, and Hariyanto (2015) with the level of treatment given to exposed individuals.

In this study, an epidemic model of the SEIT (Susceptible Exposed Infective Treatment) type was constructed with differences in the exposed period and the saturated incidence rate by providing the same level of treatment to infective individuals and exposed individuals and optimal control was carried out with the Pontryagin Maximum Principles approach to minimize the number of infective individuals and treatment costs. At the end, a numerical simulation was carried out to illustrate the results that have been obtained. The simulation results obtained from the model are used to determine the effectiveness of treatment in controlling the number of infected populations, so that the best optimal control is obtained.

## 2. RESEARCH METHOD

This research is included in basic or theoretical research. The method used is a descriptive method guided by a literature review by describing theories related to the problem of the SEIT type epidemic model, mathematical modeling and optimal control. The following are the stages in the research:

- a. Conducting a literature review related to the SEIT type epidemic problem
- b. Reviewing/creating a mathematical model of radicalization
- c. Conducting a stability analysis on the mathematical model of radicalization
- d. Completing optimal control using the Pontryagin maximum principle
- e. Conducting a simulation using Maple
- f. Comparing the simulation results on the model before and after being controlled
- g. Making conclusions

## 3. RESULTS AND DISCUSSION

### 3.1 Model Construction

Fathoni, Mardlijah, and Hariyanto (2014) have studied the SEIT type epidemic model and the population in the studied epidemic dynamic model is divided into 4 compartments, namely: Individuals who are still healthy and susceptible to disease infection enter the susceptible compartment at time  $t$  denoted by  $S(t)$ . Passively infected individuals (latent) who do not have the ability to transmit enter the exposed compartment at time  $t$  denoted by  $E(t)$ . Actively infected individuals who can transmit to other individuals enter the infected compartment at time  $t$  denoted by  $I(t)$ . Then individuals who are undergoing treatment enter the treatment compartment at time  $t$  denoted by  $T(t)$ . The total population is the sum of all compartments, namely:  $N(t) = S(t) + E(t) + I(t) + T(t)$ .

In the formation of the SEIT type epidemic mathematical model, assumptions are given so that the model formed can be limited and clarified. The assumptions made in the formation of the model are as follows:

1. Closed population
2. The natural death rate in each class is the same
3. Death occurs due to disease
4. Birth rate only in class S
5. All parameters are positive

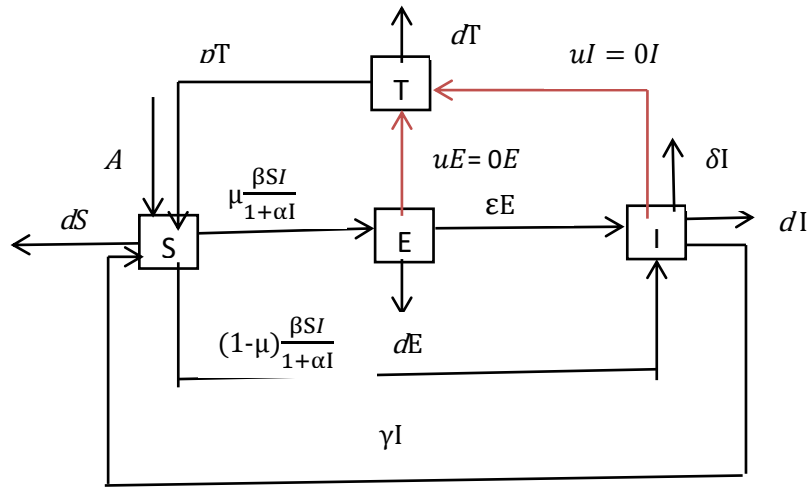

Figure 1. Schematic diagram of an uncontrolled SEIT type epidemic model

Table 1. SEIT model parameters without controls

Notation	Information
$A$	Birth rate in population
$N$	Population size
$\beta$	Transmission rate
$\mu$	The rate at which infected individuals become exposed, with $0 \leq \mu \leq 1$
$1-\mu$	Rate of infected individuals becoming infective
$D$	Natural mortality rate
$\delta$	Death rate due to disease
$\Gamma$	Rate of infective individuals becoming susceptible again
$P$	Rate of treated individuals becoming susceptible again
$\varepsilon$	Rate of exposed individuals becoming infective
$\frac{\beta SI}{1+\alpha I}$	Saturated incidence rate

Based on Figure 1, the following system of equations is obtained.

$$\dot{S}(t) = A - dS(t) - \frac{\beta S(t)I(t)}{1+\alpha I(t)} + \gamma I(t) + PT(t).$$

$$\dot{E}(t) = \mu \frac{\beta S(t)I(t)}{1+\alpha I(t)} - (d + \varepsilon)E(t).$$

$$\dot{I}(t) = (1 - \mu) \frac{\beta S(t)I(t)}{1+\alpha I(t)} + \varepsilon E(t) - (d + \gamma + \delta)I(t).$$

$$\dot{T}(t) = -(P + d)T(t).$$

### 3.2 Equilibrium Point Analysis

It is known that  $N = S + E + I + T$  then

$$\frac{dN}{dt} = \frac{dS}{dt} + \frac{dE}{dt} + \frac{dI}{dt} + \frac{dT}{dt}$$

$$\frac{dS}{dt} = \frac{dN}{dt} - \frac{dE}{dt} - \frac{dI}{dt} - \frac{dT}{dt}$$

Next,  $\frac{dN}{dt}$  will be searched to obtain the following system of equations 1:

$$\dot{E}(t) = \mu \frac{\beta I(N-E-I-T)}{1+\alpha I} - (d + \varepsilon)E.$$

$$\dot{I}(t) = (1 - \mu) \frac{\beta I(N-E-I-T)}{1+\alpha I} + \varepsilon E - (d + \gamma + \delta)I.$$

$$\dot{T}(t) = -(P + d)T.$$

$$\dot{N}(t) = A - dN - \delta I.$$

In the SEIT type epidemiological analysis, the equilibrium point and the basic reproduction number  $R_0$  are determined. The equilibrium point in equation (1) is obtained when the rate of each compartment is equal to zero. The non-endemic (disease-free) equilibrium point from equation (1) is as follows (Fathoni etc., 2014):

$$P_0 = (E_*, I_*, T_*, N_*) = (0, 0, 0, \frac{A}{d}).$$

The endemic equilibrium point (not free from disease) equation (1) is as follows.

$$P_1(E^*, I^*, T^*, N^*) \text{ with}$$

$$E^* = \frac{\mu(d + \gamma + \delta)}{(d + \varepsilon)(1 - \mu) + \mu\varepsilon} I^*$$

$$I^* = \frac{\frac{(d + \varepsilon)(d + \gamma + \delta)}{(d + \varepsilon)(1 - \mu) + \mu\varepsilon} [\frac{\beta A((d + \varepsilon)(1 - \mu) + \mu\varepsilon)}{(d + \varepsilon)(d + \gamma + \delta)d} - 1]}{\beta \left( \frac{\delta}{d} + \frac{\mu(d + \gamma + \delta)}{(d + \varepsilon)(1 - \mu) + \mu\varepsilon} + 1 \right) + \frac{\alpha(d + \varepsilon)(d + \gamma + \delta)}{(d + \varepsilon)(1 - \mu) + \mu\varepsilon}}$$

$$T^* = 0$$

$$N^* = \frac{A}{d} - \frac{\delta I^*}{d}$$

From the endemic equilibrium point, the basic reproduction number  $R_0$  is obtained.

$$R_0 = \frac{\beta A((d + \varepsilon)(1 - \mu) + \mu\varepsilon)}{(d + \varepsilon)(d + \gamma + \delta)d},$$

If  $R_0 < 1$  then the endemic equilibrium point contains a negative value, so that there is only one equilibrium point that exists, namely the disease-free equilibrium point. Whereas if  $R_0 > 1$  then there are two equilibrium points that exist, namely the disease-free equilibrium point and the endemic equilibrium point.

### 3.3 Optimal Control in the SEIT (Susceptible Exposed Infective Treatment) Type Epidemic Model with Different Exposed Periods and Saturated Incidence Levels

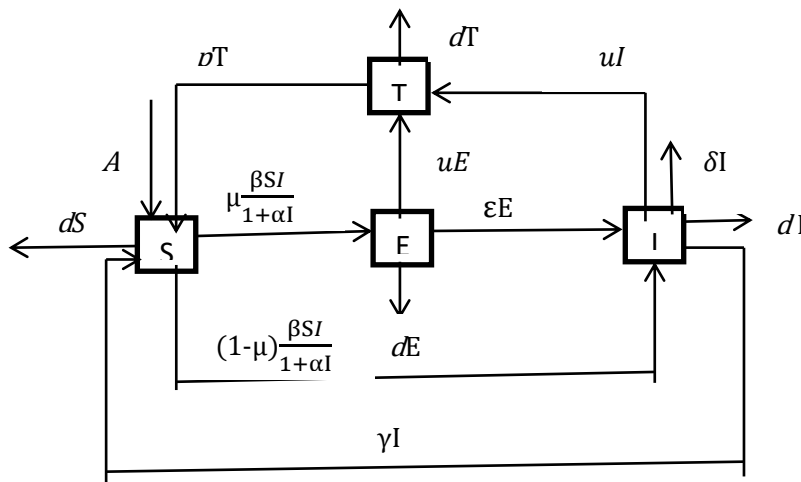

Figure 2. Schematic diagram of the SEIT type epidemic model with control assignment

Based on Figure 2, the following system of equations is obtained.

$$\dot{S}(t) = A - dS(t) - \frac{\beta S(t)I(t)}{1 + \alpha I(t)} + \gamma I(t) + PT(t).$$

$$\dot{E}(t) = \mu \frac{\beta S(t)I(t)}{1 + \alpha I(t)} - (d + \varepsilon + u)E(t).$$

$$\dot{I}(t) = (1 - \mu) \frac{\beta S(t)I(t)}{1 + \alpha I(t)} + \varepsilon E(t) - (d + \gamma + \delta + u)I(t).$$

$$\dot{T}(t) = u(E(t) + I(t)) - (P + d)T(t).$$

Where  $u$  is the same treatment rate in the infective population and in the exposed population.

Next,  $\frac{dN}{dt}$  will be searched to obtain the following system of equations.

$$\dot{E}(t) = \mu \frac{\beta I(N-E-I-T)}{1 + \alpha I} - (d + \varepsilon + u)E.$$

$$\dot{I}(t) = (1 - \mu) \frac{\beta I(N-E-I-T)}{1 + \alpha I} + \varepsilon E - (d + \gamma + \delta + u)I.$$

$$\dot{T}(t) = u(E + I) - (P + d)T.$$

$$\dot{N}(t) = A - dN - \delta I.$$

The goal achieved in the optimal control problem in this study is to obtain optimal treatment by minimizing the number of infective populations and treatment costs. Mathematically, this problem is to minimize the following objective function (Hia etc., 2012).

$$J(u_j) = \int_{t_0}^{t_f} (I(t) + \frac{C}{2} u^2(t)) dt,$$

With  $u$  is the optimal control in the model. While  $C$  is the weight on the cost of treatment,  $t_0$  is the initial time and  $t_f$  is the final time. Then we will obtain  $u_*(t)$  so that it applies

$$J(u_{j*}(t)) = \min \{J(u_j(t)) : u_j \in U\},$$

$$\text{with } U = \{u_j(t) | 0 \leq u_j \leq 0.9, t \in [0, t_f], j = 1, 2\}.$$

Since in this study a control  $u$  is given where  $u$  is the same level of treatment in the infective population and in the exposed population, then minimizing the objective function is as follows:

$$J(u) = \int_{t_0}^{t_f} (I(t) + \frac{C}{2} u^2(t)) dt,$$

The first step to study the optimal control model is to find the Lagrangian and Hamilton equations of the optimal control problem. The Lagrangian equations of the optimal control problem are:

$$L(I, u) = I(t) + \frac{C}{2} u^2$$

Then the Hamilton  $H$  function is formed as follows:

$$H = I(t) + \frac{C}{2} u^2 + \lambda_1 \frac{dE(t)}{dt} + \lambda_2 \frac{dI(t)}{dt} + \lambda_3 \frac{dT(t)}{dt} + \lambda_4 \frac{dN(t)}{dt}$$

So that the state and costate equation system is obtained as follows:

$$\dot{E}^*(t) = \mu \frac{\beta I^*(N^* - E^* - I^* - T^*)}{1 + \alpha I^*} - (d + \varepsilon + u^*)E^*$$

$$\dot{I}^*(t) = (1 - \mu) \frac{\beta I^*(N^* - E^* - I^* - T^*)}{1 + \alpha I^*} + \varepsilon E^* - (d + \gamma + \delta + u^*)I^*$$

$$\dot{T}^*(t) = u(E^* + I^*) - (P + d)T^*$$

$$\dot{N}^*(t) = A - dN^* - \delta I^*$$

$$\left(\frac{d\lambda_1}{dt}\right)^* = (\lambda_1 \mu + \lambda_2 (1 - \mu)) \frac{\beta I^*}{1 + \alpha I^*} + (\lambda_1 - \lambda_2) \varepsilon + \lambda_1 d + (\lambda_1 - \lambda_3) u$$

$$\left(\frac{d\lambda_2}{dt}\right)^* = -(\lambda_1 \mu + \lambda_2 (1 - \mu)) \frac{\beta (N^* - E^* - T^* - 2I^* - \alpha (I^*)^2)}{(1 + \alpha I^*)^2} + \lambda_2 (d + \gamma) + (\lambda_2 - \lambda_3) u$$

$$+ (\lambda_2 + \lambda_4) \delta - 1$$

$$\begin{aligned} \left(\frac{d\lambda_3}{dt}\right)_* &= (\lambda_1\mu + \lambda_2(1 - \mu)) \frac{\beta I^*}{1 + \alpha I^*} + \lambda_3(p + d) \\ \left(\frac{d\lambda_4}{dt}\right)_* &= -(\lambda_1\mu + \lambda_2(1 - \mu)) \frac{\beta I^*}{1 + \alpha I^*} + \lambda_4 d \end{aligned}$$

Stationary condition

$$\begin{aligned} \left(\frac{\partial H}{\partial u}\right)_* &= 0, \\ Cu^* - \lambda_1 E^* - \lambda_2 I^* + \lambda_3 (E^* + I^*) &= 0, \\ \bar{u}(t) &= \frac{\lambda_1(t)E^*(t) + \lambda_2(t)I^*(t) - \lambda_3(t)(E^*(t) + I^*(t))}{c}. \end{aligned}$$

Since  $0 \leq u(t) \leq 0.9$  than

$$u^*(t) = \begin{cases} 0, & \bar{u}(t) \leq 0 \\ \bar{u}(t), & 0 < \bar{u}(t) < 0.9 \\ 0.9, & \bar{u}(t) \geq 0.9 \end{cases}$$

Thus, the optimal control  $u_*(t)$  is characterized as

$$\begin{aligned} u^*(t) &= \min(0.9, \max(0, \bar{u}(t))) \\ u^*(t) &= \min \left( 0.9, \max \left( 0, \frac{\lambda_1(t)E^*(t) + \lambda_2(t)I^*(t) - \lambda_3(t)(E^*(t) + I^*(t))}{c} \right) \right) \end{aligned}$$

With boundary conditions, namely  $E(0) = E_0, I(0) = I_0, T(0) = T_0, N(0) = N_0, \lambda_1(t_f) = 0, \lambda_2(t_f) = 0, \lambda_3(t_f) = 0, \text{ dan } \lambda_4(t_f) = 0$ .

### 3.4 Numerical Simulation

To show the effect of treatment control on the model, numerical simulations were made using initial values or initial population  $(S_0, E_0, I_0, T_0, N_0) = (400, 15, 20, 0, 435)$  and parameter values that meet the endemic conditions as follows.

**Table 2.** Parameter value

Parameter	Value
A	20
d	0.0455
B	0.004
Γ	0.07
M	0.75
A	0.2
E	0.23
δ	0.1
p	0.3
C	1

Each population was simulated from the change in the number of individuals after being given a control treatment, as a comparison, the change in the number of individuals without control was included. The simulation results are shown in Figure 3 (a) – (f).

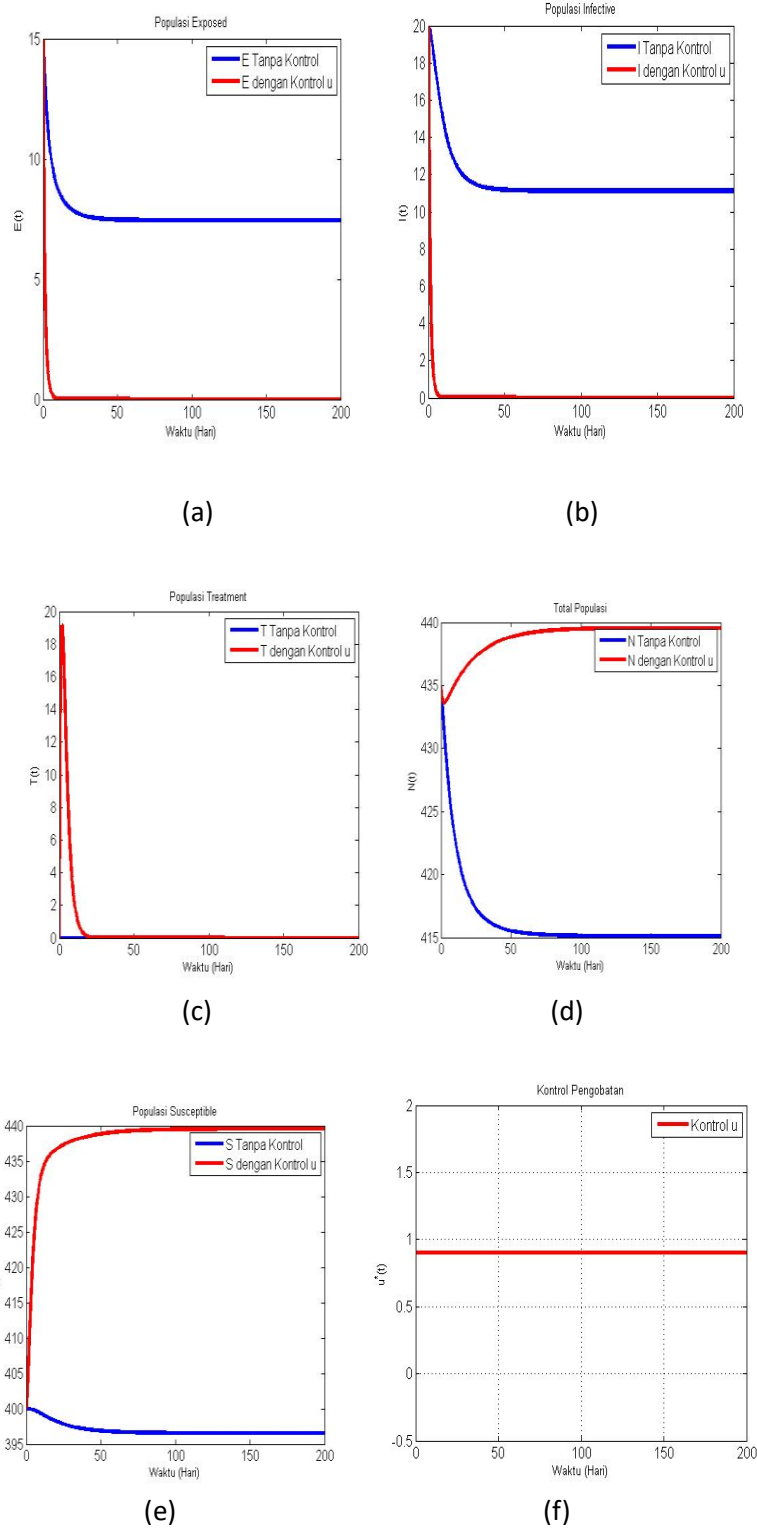

**Figure 3.** Comparison of changes in the number of individuals without and with control: (a) Exposed, (b) Infective, (c) Treatment, (d) Total Population, (e) Susceptible, (f) treatment control

Based on **Figure 3**, it is known that the number of exposed individuals and the number of infective individuals with treatment control has decreased. This is because treatment control can control the spread of a disease, thereby reducing the number of infected individuals. While the number of treatment individuals, the total population and the number of susceptible individuals with treatment control have increased. This is because treatment control can minimize treatment costs so that the number of individuals treated increases, resulting in an increase in the number of healthy individuals.

## 4. CONCLUSION

By applying the Pontryagin Maximum Principle, optimal control and system are obtained. The numerical simulations performed show results that are in accordance with the analysis results. The simulation results show the effectiveness of control in controlling the spread of a disease so that it can reduce the number of infected individuals by 91% and minimize medical costs.

## REFERENCES

- W. O. Kermack and A. G. McKendrick. (1927). "A Contribution of the Mathematical Theory of Epidemics," in *Proceedings of the Royal Society of London, Series A, Containing Papers of a mathematical and Physical Character*.
- Capasso, V. & Serio, G., (1978). A Generalization of the Kermack-McKendrick Deterministic Epidemic Model. *Mathematical Biosciences*, Volume 42. pp. 43-61.
- Fathoni, M.I.A, Mardijah and Hariyanto. (2014). "Analisis Dinamik Model Epidemi Tipe *SEIT* dengan Perbedaan Periode Laten dan Tingkat Kejadian Tersaturasi," in *Prosiding Seminar Nasional Matematika dan Pendidikan Matematika Ahmad dahlan*, ISBN No. 9772407749004.
- Wang, J., (2012). Analysis of an SEIS Epidemic Model with a Changing Delitescence. *Abstract and Applied Analysis*, pp. 1-10.
- Fathoni, M.I.A, Mardijah and Hariyanto. (2015). "Eksistensi Kontrol dan Ketunggalan Sistem Optimal Pada Model Epidemi SEIT," in *Prosiding Seminar Nasional Matematika dan Pendidikan Matematika Universitas Negeri Surabaya*. ISBN No. 978-979-028-728-0.
- M. Fan, M. Y. Li and K. Wang. (2001). "Global Stability of an SEIS Epidemic Model with Recruitment and a Varying Total Population Size," *Mathematical Biosciences*, vol. 170, pp. 199-208.
- M. El hia, O. Balatif, J. Bouyaghroumi, E. Labriji and M. Rachik. (2012). "Optimal Control Applied to the Spread of Influenza A(H1N1)," *Applied Mathematical Sciences*, vol. 6, pp. 4057-4065.